

SINRO VARIABLE AIR VOLUME UNIT

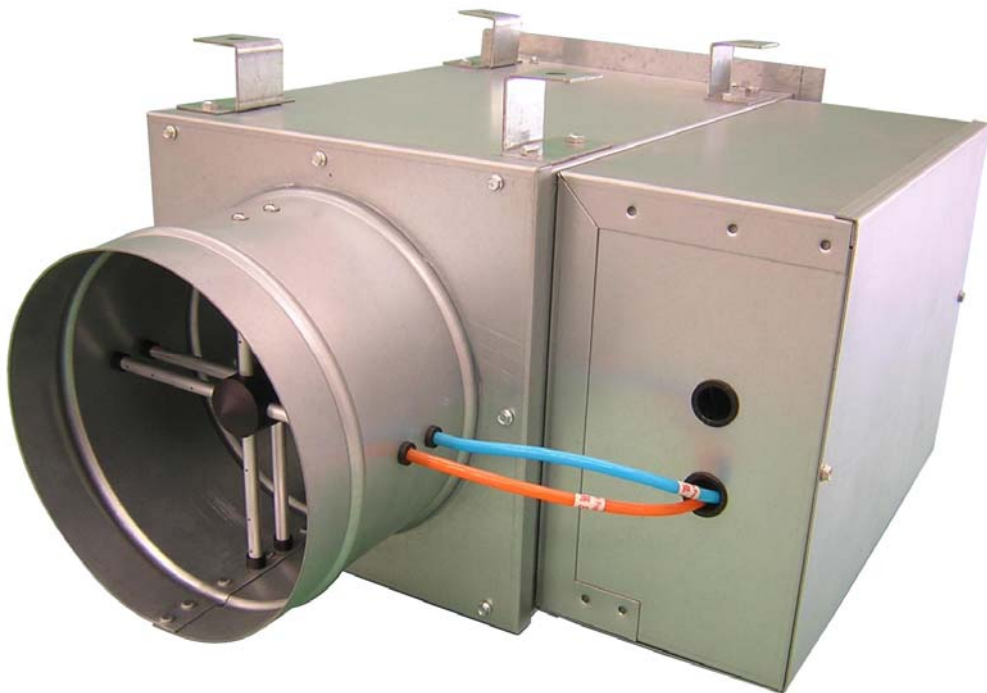

FEATURES:

Sinro VAV box can be used in low pressure or medium static pressure, single duct or double-duct system.

1. 0.8mm galvanized steel casing;
2. Can match with pneumatic Control, Analog Electronic Control or Direct Digital Control (DDC);
3. Precise size of coated galvanized steel damper plate, perfect air proof;
4. Leakage is less than 1% of max air volume at 1000Pa inlet static pressure;
5. 20mm fiberglass heat insulation layer with antiseptic treatment, in compliance with UL1181 and NFPA90A standard;
6. Applied to constant air volume air handling unit or variable air volume air handling unit.

SINRO VAV BOX MODEL NUMBER NOMENCLATURE

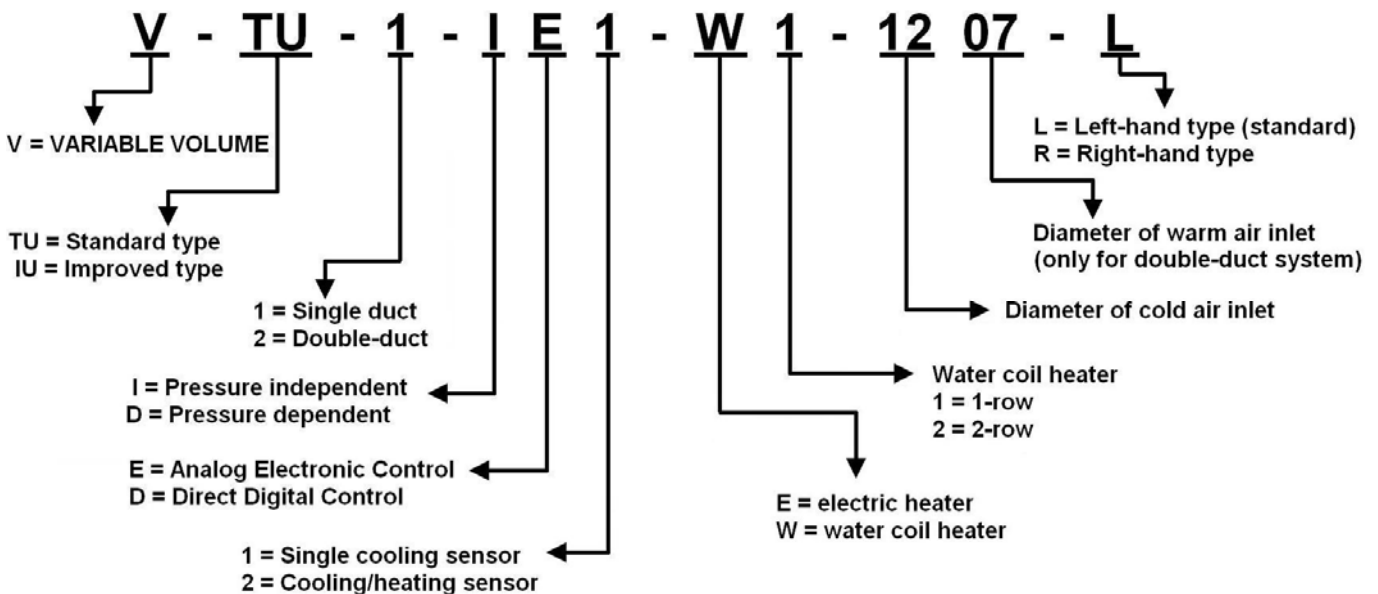

Notes: 1. Left-hand type: facing to the air outlet, the controller unit is on the left side of the box body.

2. Right-hand type: facing to the air outlet, the controller unit is on the right side of the box body.

For example:

1. V-TU-2-IE2-1008-L

Sinro standard type double-duct VAV box, pressure independent, Analog Electronic Control, cooling/heating sensor, with diameter 10 inches (10#) cold air inlet and 8 inches (8#) warm air inlet, left-hand type.

2. V-IU-1-DP1-10-R

Sinro improved type single duct VAV box, pressure dependent, Direct Digital Control, single cooling sensor, with diameter 10 inches (10#) cold air inlet, right-hand type.

SINGLE DUCT VAV BOX (SPECIFICATION & TECHNICAL DATA)

TU-1 STANDARD TYPE SINGLE DUCT VAV BOX

TU-1 standard type (square inlet and round outlet) VAV box is made by galvanized steel, and mainly used in low/medium pressure, single duct system. It can be controlled in several ways, so it is applied to constant volume system or variable volume system. There are several accessories for choice: water coil heater, electric heater, sound attenuator, multi-outlet static pressure box, medical insulation material.

The controller can be chosen/appointed by customers. They also can choose factory-mounted or to mount by themselves.

There are 11 sizes (04#-08#) with air flow of 40 to 5000 CFM (70 to 8500 CMH) for choice.

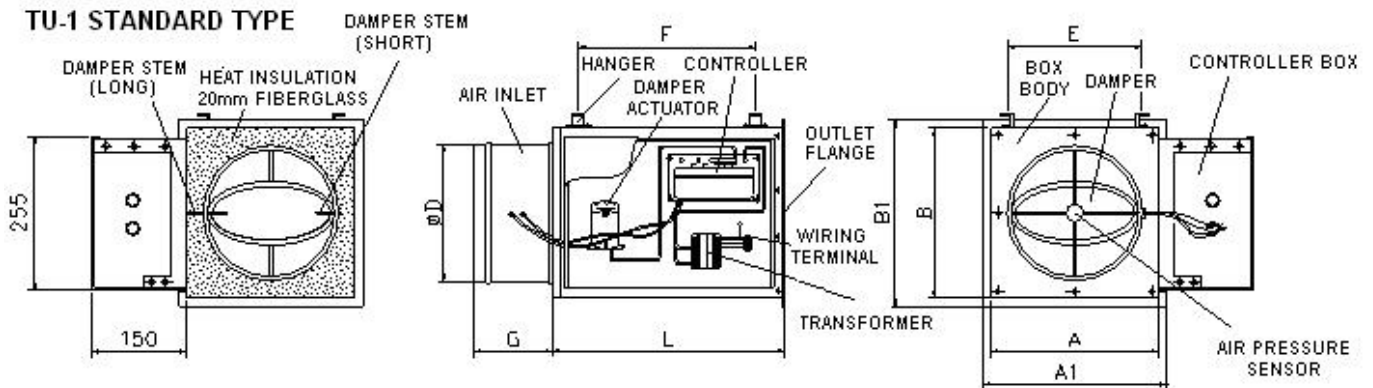

MODEL	AIR FLOW (CFM)		DIMENSIONS (mm)								
	MIN	MAX	A	B	C	D	E	F	L	G	øD
04#	40	200	209	228	252	272	169	284	402	134	99
05#	70	400									124
06#	100	600									149
07#	125	800	260	260	303	304	220				175
08#	164	1050									200
09#	226	1398	311	324	354	368	271				226
10#	275	1650									251
12#	400	2350	362	387	405	431	322				302
14#	525	3200	412	419	455	463	372				352
16#	700	4200	463	482	506	526	423				403
18#	880	5200	516	516	559	560	476				335

TU-1 IMPROVED TYPE SINGLE DUCT VAV BOX

The inlet and outlet of this VAV box is suitable for round tube, applied to the alteration of old system.

IU-1 IMPROVED TYPE

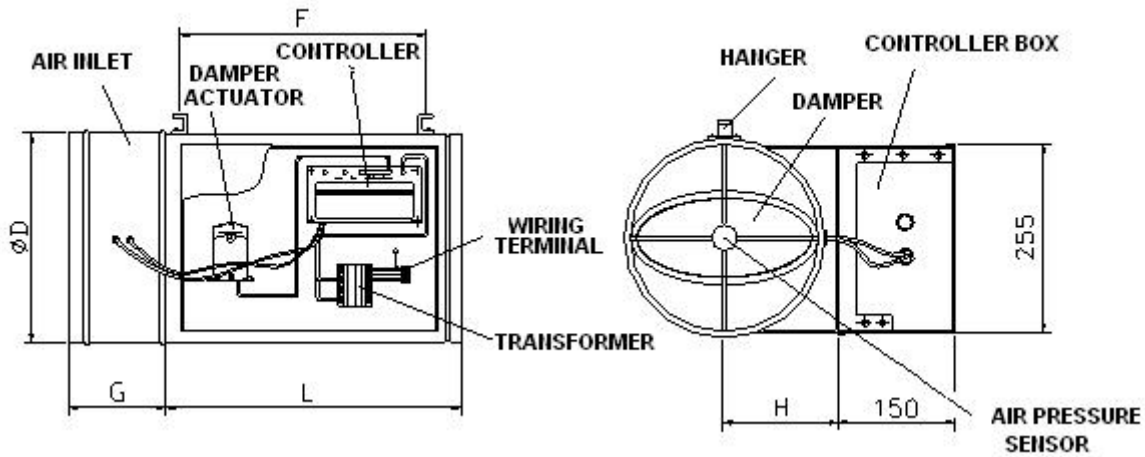

MODEL	AIR FLOW (CFM)		DIMENSIONS (mm)				
	(CMH)	(CFM)	øD	G	L	F	H
04#	40	200	99	134	402	284	49.5
05#	70	400	124				62
06#	100	600	149				74.5
07#	125	800	175				87.5
08#	164	1050	200				100
09#	226	1398	226				113
10#	275	1650	251				125.5
12#	400	2350	302				151
14#	525	3200	352				176
16#	700	4200	403				201.5
18#	880	5200	456				98

CONTROLLER

DIRECT DIGITAL CONTROL (DDC)

DDC controller is a microprocessor mounted in VAV box. The controller scans all of the inputs, performs complex calculations and commands outputs as required, sometimes communicate with external computers. The operation of the VAV box with DDC controller is completely controlled by software. The requirements can be set in factory or changed on site. All complex calculations can be done with the controller. And it is also applied to detect and control temperature in real time, can also be connected to building automatic system to achieve the functions of intelligent building.

SOUND RADIATION LEVELS (TYPE TU-1&TU-2)

SIZE	AIR FLOW		NC	▲Ps=150Pa							NC	▲Ps=200Pa							NC	▲Ps=250Pa							NC
				SOUND LEVEL(dB)								SOUND LEVEL(dB)								SOUND LEVEL(dB)							
	m³/h L/S			OCTAVE BAND(Hz)								OCTAVE BAND(Hz)								OCTAVE BAND(Hz)							
				125	250	500	1000	2000	4000	125		250	500	1000	2000	4000	125	250		500	1000	2000	4000				
4# 5#	170	47.2	<20	41.2	39.1	25.8	23.7	20.6	18.5	<20	44.1	43.3	34	28.8	27.8	23.7	<20	45.3	44.3	39.1	34	35	34	<20			
	340	94.4	<20	47.4	40.2	28.8	25.8	24.7	22.7	<20	52.5	51.5	40.2	30.9	30.9	25.8	<20	51.5	52.5	48.4	39.1	37.1	35	<20			
	510	142	<20	60.8	57.7	46.4	39.1	31.9	24.7	<20	60.8	57.7	46.4	39.1	34	29.9	24	61.8	61.8	54.6	45.3	40.2	37.1	29			
	680	189	<20	55.6	51.5	43.3	34	29.9	25.8	<20	61.8	58.7	48.4	42.2	36.1	33	25	65.9	63.9	55.6	47.4	42.2	39.1	31			
6#	255	70.8	<20	42.2	40.2	25.8	20.6	19.6	18	<20	43.3	44.3	35	29.9	29.9	24.7	<20	46.4	46.4	39.1	35	36.1	35	<20			
	510	142	<20	48.4	40.2	28.8	21.6	22.7	20.1	<20	52.5	52.5	41.2	31.9	31.9	26.8	<20	52.5	53.6	49.4	40.2	40.2	36.1	20			
	765	213	<20	61.8	58.7	47.4	40.2	33	25.8	<20	61.8	58.7	47.4	40.2	35	30.9	25	62.8	62.8	54.6	46.4	41.2	38.1	29			
	1020	283	<20	56.7	52.5	44.3	35	29.9	26.8	<20	62.8	59.7	49.4	43.3	37.1	34	26	68	64.9	55.6	48.4	43.3	40.2	30			
7#	340	94.4	<20	47.8	38.5	28.1	25	21.8	<20	49.9	46.8	37.4	32.2	30.2	28.1	<20	53	49.9	42.6	37.4	38.5	32.2	<20				
	680	189	<20	52	41.6	33.3	26	23.9	20.8	<20	59.3	54.1	44.7	34.3	31.2	29.1	<20	62.4	60.3	54.1	44.7	39.5	35.4	26			
	1020	283	<20	55.6	48.4	39.1	33	27.8	24.7	<20	63.9	55.6	48.4	40.2	36.1	32.2	24	70	63.9	55.6	48.4	44.3	40.2	31			
	1360	378	<20	56.7	52.5	44.3	35	29.9	26.8	<20	65.9	59.7	50.5	43.3	39.1	34	26	71.1	64.9	56.7	49.4	45.3	41.2	32			
8#	450	125	<20	48.4	39.1	28.8	25.8	22.7	<20	50.5	47.4	38.1	30.9	31.9	29.9	<20	53.6	50.5	44.3	38.1	37.6	26.3	<20				
	900	250	<20	51.5	42.2	34	26.8	24.7	23.8	<20	59.7	54.6	45.3	35	31.9	29.9	20	62.8	60.8	54.6	45.3	40.2	31.6	23			
	1350	375	<20	56.7	67.3	40.2	34	28.8	25.8	<20	64.9	57.7	49.4	41.2	37.1	34	26	70.8	64.9	55.6	49.4	45.3	36.4	32			
	1800	500	<20	60.8	54.6	46.4	40.2	35	30.9	<20	68	60.8	51.5	44.3	40.2	35	28	72.1	65.9	57.7	50.5	45.3	41.2	34			
9# 10#	595	165	<20	46.4	41.2	31.9	26.8	24.7	22.7	<20	52.5	54.6	46.4	39.1	37.1	35	20	56.7	57.7	56.7	49.4	44.3	43.3	27			
	1190	331	<20	52.5	48.4	41.2	38.1	33	26.8	<20	58.7	56.7	48.4	43.3	39.1	39.1	21	60.8	62.8	57.7	53.6	47.4	46.4	30			
	1785	496	<20	55.6	51.5	41.2	36.1	33	30.9	<20	61.8	58.7	50.5	45.3	40.2	40.2	26	62.8	63.9	57.7	54.6	48.4	47.4	31			
	2380	661	<20	58.7	54.6	44.3	39.1	37.1	34	<20	63.9	59.7	51.5	46.4	42.2	41.2	28	65.9	64.9	58.7	54.6	48.4	47.4	32			
12#	1000	278	<20	53.6	45.3	38.1	30.2	25.3	20.7	<20	56.9	53.6	41.8	37.6	33.3	26.9	24	57.7	55.7	45.4	39.1	34.1	29.3	31			
	2000	556	<20	55.6	48.4	40.2	35.3	27.6	22.2	<20	60.9	57.2	48.6	43.5	37.2	30.6	25	62.7	59.9	50.3	44.3	44.3	32.3	32			
	3000	833	<20	59.7	51.5	43.3	38.1	31.4	19.1	<20	65.9	59.7	52.5	46.4	43.3	36.8	26	68.1	64.4	55.4	49.3	42.8	34.1	34			
	4000	1111	<20	63.9	54.6	46.4	42.2	38.1	26.9	24	69	61.8	54.6	48.4	46.4	39.9	30	72.1	69.8	60.9	55.2	49.1	40.6	36			
14#	1350	375	<20	54.6	46.4	39.1	32	29.1	29.1	<20	59.2	55.3	49.5	42.6	38.8	38.8	25	62.1	60.2	57.3	52.4	46.6	46.6	32			
	2700	750	<20	56.2	48.6	40.5	34.4	32.6	31.7	<20	64.9	59.7	50.5	46.4	39.8	39	26	66	62.1	58.3	52.4	47.6	45.6	34			
	4050	1125	<20	60.8	52.5	44.4	39.1	35	34	<20	67	60.8	53.6	47.4	43.3	43.3	27	72.1	67	62.8	56.7	51.5	50.5	35			
	5400	1500	<20	63.9	55.6	47.4	43.3	39.1	37.1	24	70	62.8	55.6	49.4	46.4	45.3	31	74.2	68	63.9	57.7	52.5	51.5	38			
16#	1785	496	<20	46.4	41.2	31.6	26.8	24.7	23.7	<20	52.5	54.6	46.4	39.1	37.1	35	21	56.7	57.7	56.7	49.4	44.3	43.3	27			
	3570	992	<20	52.5	48.4	41.2	38.1	33	28.8	<20	58.7	56.7	48.4	43.3	39.1	39.1	23	60.8	62.8	57.7	53.6	47.4	46.4	30			
	5355	1488	<20	55.6	51.5	41.2	37.1	33	30.9	<20	61.8	58.7	50.5	45.3	40.2	40.2	25	62.8	63.9	57.8	54.6	48.4	47.4	31			
	7140	1983	<20	58.7	54.6	44.3	39.1	37.1	34	<20	63.9	59.7	51.5	46.4	42.2	41.2	26	65.9	64.9	58.7	54.6	49.4	48.4	32			
18#	2213	614.7	<20	40.2	38.1	28.6	24.8	22.7	20.6	<20	50.5	51.5	44.3	37.1	36.1	33	21	54.6	53.6	51.5	48.4	42.3	40.2	28			
	4425	1229	<20	50.5	46.4	29.9	36.1	30.9	26.8	<20	56.7	54.6	46.4	41.2	37.1	36.1	25	56.9	55.3	56.2	53.5	46.4	44.3	30			
	6638	1844	<20	51.5	47.4	36.1	37.1	31.9	26.8	<20	60.8	57.2	48.4	42.4	38.1	37.5	30	62.4	61.8	56.8	52.5	46.4	45.3	35			
	8850	2458	<20	54.6	53.6	42.2	38.1	35	33	<20	61.8	58.7	49.4	43.4	39.6	40.8	28	64.3	63.9	57.7	53.6	49.4	45.9	35			

▲PS=INLET STATIC PRESSURE _ =SOUND POWER LEVELS IS LESS THAN 20

Table A: Sound power (dB) absorbed by architectural material

FREQUENCY	125	250	500	1000	2000	4000
ATTENUATION RATE	9	10	12	14	15	15

- Notes: 1. Test data obtained in accordance with ADC/ARI-800
 2. All NC sound power levels are tested in the condition which is assumed 10dB sound power would be absorbed by architectural material, and as the conditions listed in Table A.
 3. Minimum static pressure is the pressure got at inlet when the damper is fully open.

OUTLET SOUND POWER LEVELS (TYPE TU-1&TU-2)

SIZE	AIR FLOW		NC	▲Ps=150Pa							NC	▲Ps=200Pa							NC	▲Ps=250Pa							NC
				SOUND LEVEL(dB)								SOUND LEVEL(dB)								SOUND LEVEL(dB)							
	OCTAVE BAND(Hz)							OCTAVE BAND(Hz)							OCTAVE BAND(Hz)												
	M ³ /H	L/S		125	250	500	1000	2000	4000	125		250	500	1000	2000	4000	125	250		500	1000	2000	4000				
4"	170	47	<20	55.6	44.3	40.2	39.1	34.3	31.9	<20	56.7	54.6	51.5	48.4	46.4	46.4	<20	60.8	57.7	54.6	51.5	52.5	50.5	<20			
	340	94	<20	60.8	47.4	42.2	40.2	35.4	33	<20	65.9	65.9	58.7	52.5	47.4	47.4	<20	65.9	69	67	58.7	55.6	54.6	<20			
	510	142	<20	62.8	54.6	53.6	50.5	42.2	38.1	<20	75.2	70	63.9	58.7	51.5	51.5	<20	77.3	77.3	72.1	65.9	58.7	59.7	<20			
	680	189	<20	68	59.7	57.7	54.6	45.3	41.2	<20	77.3	72.1	65.9	61.8	54.6	52.5	<20	80.3	78.3	73.1	68	60.8	58.7	20			
6"	255	71	<20	58.7	51.5	43.3	40.2	38.1	38.1	<20	65.9	63.9	58.7	53.6	51.5	51.5	<20	68	69	64.9	59.7	59.7	57.8	<20			
	510	142	<20	60.8	51.5	47.4	44.3	40.2	40.2	<20	77.3	71.1	62.8	54.6	51.5	52.5	<20	79.3	80.3	76.2	64.9	60.8	59.7	22			
	765	213	<20	65.9	58.7	55.6	52.5	45.3	43.3	<20	81.4	72.1	63.9	58.7	54.6	55.6	<20	86.5	82.4	75.2	64.9	60.8	60.8	25			
	1020	283	<20	69	61.8	47.4	54.6	46.4	44.3	<20	80.3	71.1	63.9	60.8	54.6	55.6	<20	88.6	82.4	74.2	67	61.8	61.8	26			
7"	340	94	<20	57.7	49.4	42.2	39.1	37.1	37.1	<20	65.9	62.8	57.7	51.5	50.5	50.5	<20	65.2	67	63.9	59.7	58.7	55.6	<20			
	680	189	<20	59.7	50.5	47.4	43.3	39.1	39.1	<20	76.2	70	61.8	53.6	51.5	51.5	<20	78.3	73.1	74.2	62.8	59.7	58.7	<20			
	1020	283	<20	64.9	58.7	54.6	51.5	45.3	42.2	<20	79.3	71.1	62.8	56.7	53.6	54.6	<20	84.7	77.3	75.2	63.9	60.8	59.7	21			
	1360	378	<20	67	60.8	56.7	54.6	46.4	43.3	<20	80.3	71.1	63.9	59.7	54.6	54.6	<20	87.6	80.3	74.2	66.1	61.8	60.8	25			
8"	450	125	<20	58.7	51.5	43.3	40.2	38.1	38.1	<20	65.9	63.9	58.7	53.6	51.5	51.5	<20	68	69	64.9	59.7	59.7	57.7	<20			
	900	250	<20	60.8	51.5	47.4	44.3	40.2	40.2	<20	77.3	71.1	62.8	54.6	51.5	52.5	<20	79.3	80.3	76.2	64.9	60.8	59.7	22			
	1350	375	<20	65.9	58.7	55.6	52.5	45.3	43.3	<20	81.4	72.1	63.9	58.7	54.6	55.6	<20	86.5	82.4	75.2	64.9	60.8	60.8	25			
	1800	500	<20	69	61.8	57.7	54.6	46.4	44.3	<20	80.3	71.1	63.9	60.8	54.6	55.6	<20	88.6	82.4	74.2	67	61.8	61.8	26			
10"	595	165	<20	57.7	50.5	46.4	41.2	38.1	39.1	<20	67	68.9	61.2	53.4	49.5	50.5	<20	68	73.8	71.8	68	58.3	57.3	<20			
	1190	331	<20	63.9	57.7	52.5	47.4	42.2	42.2	<20	70.9	67	60.2	55.3	51.5	52.4	<20	73.8	77.7	73.8	65	59.2	58.3	26			
	1785	496	<20	65.9	59.7	54.6	49.4	43.3	43.3	<20	72.8	67	61.2	56.3	52.4	52.4	<20	75.7	76.7	70.9	64.1	59.2	59.2	24			
	2380	661	<20	69	63.9	57.7	52.5	46.4	45.3	<20	74.8	68	62.1	58.3	53.4	53.4	<20	77.7	76.7	70.9	65	60.2	59.2	23			
12"	1000	278	<20	59.7	53.6	50.5	43.3	39.1	40.2	<20	62.4	69.3	56.4	52.3	49.4	44.7	<20	65.2	66.8	60.3	55.2	51.6	47.8	<20			
	2000	556	<20	62.6	58.7	54.6	48.4	44.3	43.3	<20	63.8	66.5	62.8	57	52.9	48	<20	65.9	68.2	63.9	60.1	54.9	50.2	<20			
	3000	833	<20	67	61.8	56.7	50.5	45.3	44.3	<20	69.1	68.7	65.3	60.8	56.2	50.7	<20	70.5	71.3	67.6	63.6	58.2	53.1	20			
	4000	1111	<20	71.1	65.9	62.8	55.6	50.5	49.4	<20	73.2	72.6	68.9	63.6	58.4	53.2	<20	74.5	73.8	70	65.9	60.8	55.6	21			
14"	1350	375	<20	58.3	52.4	49.5	42.7	38.8	39.8	<20	67	64.1	62.1	55.3	50.5	52.4	<20	72.8	74.8	72.8	66	60.2	58.3	21			
	2700	750	<20	61.2	55.3	53.4	45.6	41.7	42.7	<20	68.9	65	63.1	56.3	51.5	53.4	<20	74.8	73.8	71.8	67	61.2	59.2	22			
	4050	1125	<20	65	59.2	59.7	49.5	44.7	44.7	<20	71.8	67	64.1	57.3	49.5	54.4	<20	76.7	73.8	71.8	67	62.1	60.2	22			
	5400	1500	<20	68	63.1	60.2	53.4	48.5	48.5	<20	73.8	68.9	66	59.2	53.4	55.3	<20	78.6	74.8	71.8	66	61.2	61.2	21			
16"	1785	496	<20	59.2	56.7	50.5	43.7	39.8	40.8	<20	68	65	62.1	56.3	51.5	53.4	<20	73.8	75.7	73.8	68	61.2	60.2	23			
	3570	992	<20	61.2	55.3	53.4	45.6	41.7	42.7	<20	68.9	65	63.1	56.3	51.5	53.4	<20	74.8	73.8	71.8	67	61.2	61.2	20			
	5355	1488	<20	66	60.2	55.3	50.5	48.4	43.7	<20	72.8	68	64.1	58.3	53.4	52.4	<20	76.7	73.8	70.9	68	62.1	62.1	20			
	7140	1983	<20	68	63.1	60.2	53.4	51.5	48.5	<20	73.8	68.9	66	59.2	53.4	55.3	<20	78.6	74.8	71.8	66	61.2	63.1	21			
18"	2213	614.7	<20	60.2	57.7	51.5	44.7	40.8	41.7	<20	68.9	66	63.1	57.3	52.4	54.4	<20	74.8	75.5	74.8	68.6	61.4	61.2	23			
	4425	1229	<20	62.1	56.3	54.4	46.6	42.7	43.7	<20	69.9	66	64.1	57.3	53.4	54.8	<20	76.7	74.8	72.8	68	62.1	61.8	20			
	6638	1844	<20	68.9	61.2	56.3	51.5	49.4	44.7	<20	73.8	68.9	65	60.2	55.3	53.4	<20	77.7	74.5	72.8	68.6	63.1	62.7	20			
	8850	2458	<20	69.9	64.1	61.2	54.4	53.6	49.5	<20	74.8	69.9	66.1	61.2	56.3	53.4	<20	79.4	75.7	73.8	69.3	62.1	63.7	21			

▲PS=INLET STATIC PRESSURE _ =SOUND POWER LEVELS IS LESS THAN 20

Table A: The absorbed sound power (dB) after going through 5' outlet metal duct or 6' canvas tube

FREQUENCY	125	250	500	1000	2000	4000
ATTENUATION RATE	9	10	12	14	15	15

Table B: The sound power (dB) reverberated by box body or absorbed by 3-way elbow

FREQUENCY	125	250	500	1000	2000	4000
ATTENUATION RATE	12	9	9	9	6	8

Table C: The sound power attenuated during the distribution of air flow

MODEL	5# & 6#	7# & 8#	10#	12#	14#	16#
DISTRIBUTION RATIO (%)	50	40	30	20	15	10
ATTENUATION RATE	3	4	5	7	8	10

Notes: 1. Test data obtained in accordance with ADC/ARI-800

2. All NC sound power levels are tested in the condition which is assumed 10dB sound power would be absorbed by architectural material, and as the conditions listed in Table A, B and C.

HOT WATER COIL

Hot water coil is installed in the galvanized steel frame, and made by the sizes of TU-1 and ML-1 VAV box. Hot water coil heater is suitable for large size central air conditioning system. If hot water supply is convenient in application, it is also suitable for small system. The coil connectors obtain in accordance with SLIP and DRIVE Standard.

STANDARD CONFIGURATION:

- ◆ Galvanized steel frame
- ◆ Copper pipe size: 3/8"
- ◆ Ordinary aluminum fin 0.115,10FPI
- ◆ Inlet / outlet water pipe size: G3/4"
- ◆ Exhaust valve
- ◆ Inlet /outlet flange

OPTIONAL ACCESSORIES

- ◆ Motorized 2-way or 3-way valve

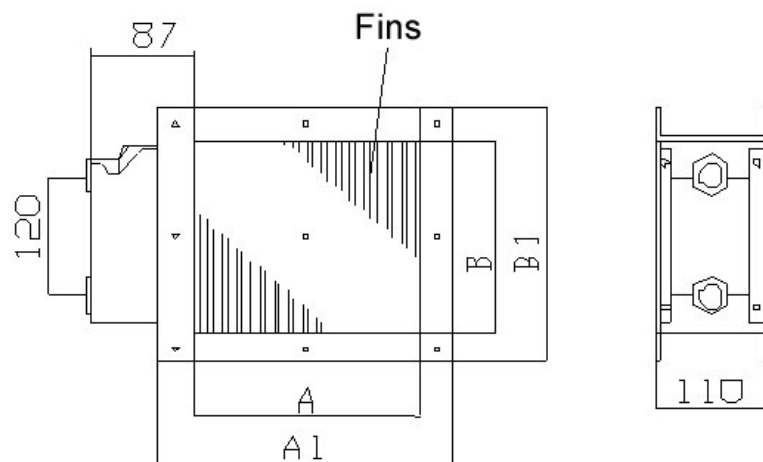

DIMENSION

MODEL	COIL ROWS	A(MM)	B(MM)	A1(MM)	B1(MM)
4~6	1 row/2 row	209	228	252	272
7~8	1 row/2 row	260	260	303	304
9~10	1 row/2 row	311	324	354	368
12	1 row/2 row	362	387	405	431
14	1 row/2 row	463	482	506	526
16	1 row/2 row	516	516	559	560

HOT WATER COIL DATA

SIZE	ROWS	WATER FLOW RATE (l/s)	WATER RESISTANCE (mmH2O)	AIR FLOW (CFM)				
				170	340	510	680	850
				PRESSURE DROP (mmH2O)				
				0.8	1.3	2.5	3.8	5.3
5	1-ROW	0.03	2.0	HEAT CAPACITY (Kw)				
		0.06	7.4	1.6	2.0	2.3	2.5	2.8
		0.13	24.9	1.8	2.2	2.7	3.0	3.3
		0.32	85.1	2.1	2.6	3.2	3.8	4.0
				PRESSURE DROP (mmH2O)				
				1.3	2.3	4.8	7.4	10.2
6	2-ROW	0.06	2.0	HEAT CAPACITY (Kw)				
		0.13	7.4	2.6	3.6	4.3	4.9	5.4
		0.32	37.1	3.1	4.3	5.1	5.8	6.4
		0.64	126.2	3.9	5.4	6.4	7.3	8.1
				PRESSURE DROP (mmH2O)				
				4.7	6.4	7.6	8.7	9.6

SIZE	ROWS	WATER FLOW RATE (l/s)	WATER RESISTANCE (mmH2O)	AIR FLOW (CFM)				
				510	680	850	1070	1190
				PRESSURE DROP (mmH2O)				
				0.5	1.0	2.0	3.3	5.1
7	1-ROW	0.03	2.8	HEAT CAPACITY (Kw)				
		0.06	9.4	2.7	3.0	3.2	3.5	3.7
		0.13	32.5	3.2	3.5	3.8	4.1	4.4
		0.32	110.5	3.6	4.1	4.5	4.9	5.3
				PRESSURE DROP (mmH2O)				
				1.0	1.8	3.8	6.4	9.9
8	2-ROW	0.06	2.8	HEAT CAPACITY (Kw)				
		0.13	9.4	5.2	5.8	6.2	6.7	7.1
		0.32	48.3	6.3	6.7	7.3	7.9	8.5
		0.64	138.7	7.6	8.4	9.2	10.0	10.7
				PRESSURE DROP (mmH2O)				
				9.0	9.9	10.9	11.9	12.7

SIZE	ROWS	WATER FLOW RATE (l/s)	WATER RESISTANCE (mmH2O)	AIR FLOW (CFM)				
				510	850	1190	1530	1870
				PRESSURE DROP (mmH2O)				
				1.3	2.0	3.0	4.3	6.1
10	1-ROW	0.03	1.3	HEAT CAPACITY (Kw)				
		0.06	13.5	3.0	3.7	4.3	4.8	5.3
		0.13	45.7	3.5	4.4	5.2	5.8	6.3
		0.32	130.0	4.2	5.3	6.1	6.9	7.5
				PRESSURE DROP (mmH2O)				
				2.3	3.6	6.1	8.4	11.9
10	2-ROW	0.06	3.8	HEAT CAPACITY (Kw)				
		0.13	13.5	5.7	7.1	8.3	9.3	10.1
		0.32	67.8	6.8	8.4	9.9	11.0	12.1
		0.64	179.8	8.5	10.7	12.4	13.9	15.2
				PRESSURE DROP (mmH2O)				
				10.1	12.7	14.7	16.5	18.0

SIZE	ROWS	WATER FLOW RATE (l/s)	WATER RESISTANCE (mmH2O)	AIR FLOW (CFM)				
				1020	1360	1700	2040	2380
				PRESSURE DROP (mmH2O)				
				1.0	1.8	2.5	3.8	5.1
12	1-ROW	0.03	5.3	HEAT CAPACITY (Kw)				
		0.06	17.8	4.6	5.2	5.7	6.2	6.7
		0.13	60.7	5.4	6.2	6.8	7.4	7.9
		0.32	181.1	6.5	7.4	8.1	8.8	9.4
				PRESSURE DROP (mmH2O)				
				1.8	3.6	4.8	7.4	9.9
12	2-ROW	0.06	5.3	HEAT CAPACITY (Kw)				
		0.13	17.8	8.8	10.0	11.0	12.0	12.8
		0.32	64.5	10.4	11.9	13.1	14.2	15.2
		0.64	205.0	13.1	14.9	16.5	17.8	19.1
				PRESSURE DROP (mmH2O)				
				15.6	17.7	19.6	21.2	22.7

SIZE	ROWS	WATER FLOW RATE (l/s)	WATER RESISTANCE (mmH2O)	AIR FLOW (CFM)				
				1360	2040	2720	3400	4080
				PRESSURE DROP (mmH2O)				
				1.5	3.0	4.6	5.3	6.9
14	1-ROW	0.03	6.1	HEAT CAPACITY (Kw)				
		0.06	21.1	5.6	6.7	7.7	8.5	9.2
		0.13	71.6	6.7	8.0	9.1	10.1	10.9
		0.32	218.9	8.0	9.6	10.8	12.0	13.0
				PRESSURE DROP (mmH2O)				
				2.8	5.3	8.9	10.2	13.2
14	2-ROW	0.06	6.1	HEAT CAPACITY (Kw)				
		0.13	21.1	11.4	13.5	15.3	16.8	18.2
		0.32	81.0	13.4	15.9	18.0	19.9	21.5
		0.64	261.1	16.7	19.5	22.5	24.8	26.9
				PRESSURE DROP (mmH2O)				
				19.7	23.5	26.7	29.4	31.8

SIZE	ROWS	WATER FLOW RATE (l/s)	WATER RESISTANCE (mmH2O)	AIR FLOW (CFM)				
				1700	2380	3060	3740	4420
				PRESSURE DROP (mmH2O)				
				1.0	1.8	2.8	3.8	5.1
16	1-ROW	0.03	7.6	HEAT CAPACITY (Kw)				
		0.06	23.5	6.9	8.0	8.9	9.7	10.5
		0.13	64.5	8.1	9.5	10.6	11.6	12.5
		0.32	230.1	9.7	11.3	12.6	13.7	14.8
				PRESSURE DROP (mmH2O)				
				1.8	3.6	4.8	7.4	9.9
16	2-ROW	0.06	7.6	HEAT CAPACITY (Kw)				
		0.13	26.4	13.1	15.2	17.1	18.6	20.1
		0.32	107.9	15.6	18.1	20.3	22.2	23.9
		0.64	276.9	19.6	22.8	25.5	27.8	30.0
				PRESSURE DROP (mmH2O)				
				23.3	27.0	30.3	33.1	35.7

SIZE	ROWS	WATER FLOW RATE (l/s)	WATER RESISTANCE (mmH2O)	AIR FLOW (CFM)					
				3400	4250	5100	5950	7650	
24x16	1-ROW	0.03	6.9	PRESSURE DROP (mmH2O)					
		0.06	23.1	1.8	2.3	3.3	4.6	5.6	
		0.13	91.7	HEAT CAPACITY (Kw)					
		0.32	272.5	14.0	15.4	16.8	17.9	20.1	
					16.6	18.3	19.9	21.3	23.9
					20.9	23.1	25.0	26.8	30.0
				24.8	27.4	29.7	31.8	35.6	
				PRESSURE DROP (mmH2O)					
				3.3	4.3	6.4	9.1	10.9	
2-ROW			1.5	HEAT CAPACITY (Kw)					
			6.9	22.5	24.9	27.0	28.9	32.3	
			34.3	26.8	29.6	32.1	34.3	38.4	
			117.1	33.6	37.2	40.3	43.2	48.3	
				40.0	44.2	47.9	51.3	57.4	
SIZE	ROWS	WATER FLOW RATE (l/s)	WATER RESISTANCE (mmH2O)	AIR FLOW (CFM)					
18	1-ROW	0.03	0.0	PRESSURE DROP (mmH2O)					
		0.06	152.0	1.5	3.8	6.4	9.6	13.4	
		0.13	488.0	HEAT CAPACITY (Kw)					
		0.32	2468.0	6.1	6.5	6.1	6.8	6.9	
					6.8	10.4	11.1	11.8	11.9
					12.2	14.4	15.8	16.8	17.6
				14.7	17.9	20.2	22.1	23.6	
				PRESSURE DROP (mmH2O)					
				3.3	7.4	6.4	19.0	26.6	
2-ROW			7.6	HEAT CAPACITY (Kw)					
			26.4	13.2	14.3	14.8	15.2	15.4	
			107.9	19.3	22.6	24.4	25.8	26.7	
			276.9	23.8	29.8	33.5	36.5	38.8	
				26.2	33.7	39.2	43.8	47.1	

The calculation of hot water coil data above are in accordance with ARI410-81. The above data are calculated based on the entering water temperature 82.2°C, and heat coil entering air temperature 12.8°C. If the actual temperature difference is less than 69.4°C, the factors below should be considered for getting the actual heating capacity.

Table D: Temperature differences correction factors

Δ T (°C)	27.8	33.3	38.9	44.4	50	55.6	61.1	69.4	77.7	83.3
Factor	0.4	0.48	0.56	0.64	0.72	0.8	0.88	1	1.12	1.2

Table E: Radiate Noise

9	430	30	24	—	—	—	—	<20	45	40	29	25	—	—	<20	47	48	41	35
	860	39	32	35	—	—	—	<20	49	45	38	35	29	—	<20	58	55	48	40
	1350	47	38	31	31	27	—	<20	53	49	40	36	32	29	<20	61	58	50	45
	1800	51	43	36	37	33	27	<20	54	51	42	37	34	31	<20	63	58	50	45

Table F: Outlet Noise

9	430	38	29	26	—	—	—	<20	56	49	43	39	37	37	<20	65	65	59	52
	860	50	44	41	35	31	25	<20	60	54	49	44	38	37	<20	74	69	61	55
	1350	59	52	49	43	39	34	<20	63	57	53	49	42	41	22	76	70	63	59
	1800	64	57	55	50	45	41	23	64	60	55	50	43	42	24	78	70	64	60

ACCESSORIES

1. HOT WATER COIL HEATER

Hot water coil is installed in the galvanized steel frame, and made by TU-1 VAV box size. Hot water coil heater is suitable for large size central air conditioning system. If hot water supply is quite convenient, it is also suitable for small system. Every coil connector obtains in accordance with SLIP and DRIVE Standard.

STANDARD CONFIGURATION:

- ◆ Galvanized steel frame
- ◆ Copper pipe size: DN15
- ◆ Test pressure is 1.7MPa
- ◆ Coil connectors obtain in accordance with SLIP and DRIVE Standard
- ◆ Copper pipes are fixed through ripple aluminum fins in mechanical expanded pipe method. 12 fins/inch

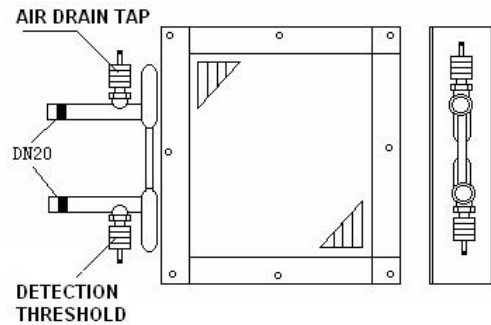

OPTIONAL ACCESSORIES

- ◆ Hot water coil (factory-mounted)
- ◆ Motorized 2-way or 3-way valve

2. ELECTRIC HEATER COIL

Electric heater coil is suitable for small VAV system, or in the situation of lacking hot water. All electric heater coils are factory-mounted in outspread frame for reducing on site labor cost, and obtain NEC (National Electrical Code).

STANDARD CONFIGURATION:

- ◆ Square air inlet and outlet
- ◆ Inlet /outlet flange
- ◆ Detachable configuration

OPTIONAL ACCESSORIES

- ◆ Round air inlet and outlet
- ◆ coil connectors obtain in accordance with SLIP and DRIVE Standard
- ◆ Integrative configuration

SIZE	ELECTRIC HEATER COIL DATA					
5" & 6"	AIR FLOW (CFM)	100	200	300	400	500
	MAX POWER (Kw)	1.4	2.9	4.3	5.7	7.1
7" & 8"	AIR FLOW (CFM)	300	400	500	600	700
	MAX POWER (Kw)	4.3	5.7	7.1	8.6	10.0
10"	AIR FLOW (CFM)	300	500	700	900	1100
	MAX POWER (Kw)	4.3	7.1	10.0	12.9	15.7
12"	AIR FLOW (CFM)	600	800	1000	1200	1400
	MAX POWER (Kw)	8.6	11.4	14.3	17.1	20.0
14"	AIR FLOW (CFM)	800	1200	1600	2000	2400
	MAX POWER (Kw)	11.4	11.7	22.9	28.6	34.3
16"	AIR FLOW (CFM)	1000	1400	1800	2200	2600
	MAX POWER (Kw)	14.3	20.0	25.7	31.4	37.1
24"×16"	AIR FLOW (CFM)	2000	2500	3000	3500	4484
	MAX POWER (Kw)	28.6	35.7	42.9	50.0	64.3

Dimension

Model	A(mm)	B(mm)	A1(mm)	B1(mm)	C(mm)
4—6#	209	228	252	272	50
7—8#	260	260	303	304	50
9—10#	311	324	354	368	50
12#	362	387	405	431	50
14#	412	419	455	463	50
16#	463	482	506	526	50
18#	516	516	559	560	50

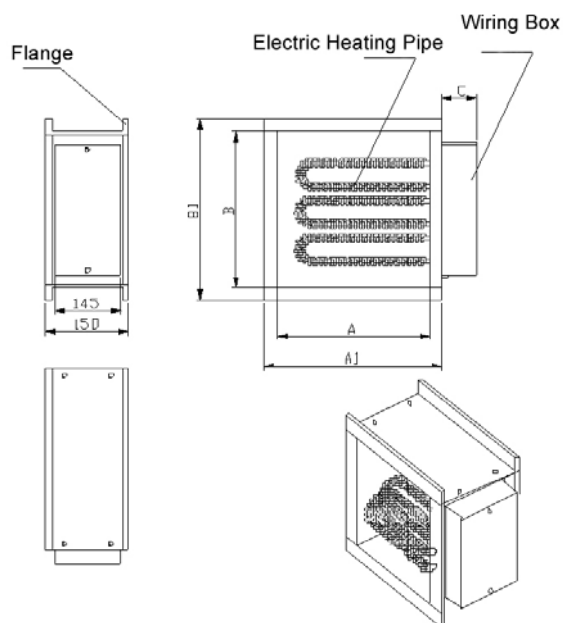

3. SOUND ATTENUATOR

Sound attenuator is used for reducing noise from air flow. It adopts modularization design, uses flange connection as the standard figuration. It is easy installation and has excellent sealing.

STANDARD CONFIGURATION:

- ◆ 0.8mm galvanized steel casing
- ◆ Inside galvanized microporous sheet
- ◆ Noise reduction material is 20mm super-thin fiberglass
- ◆ Connectors obtain in accordance with SLIP and DRIVE Standard

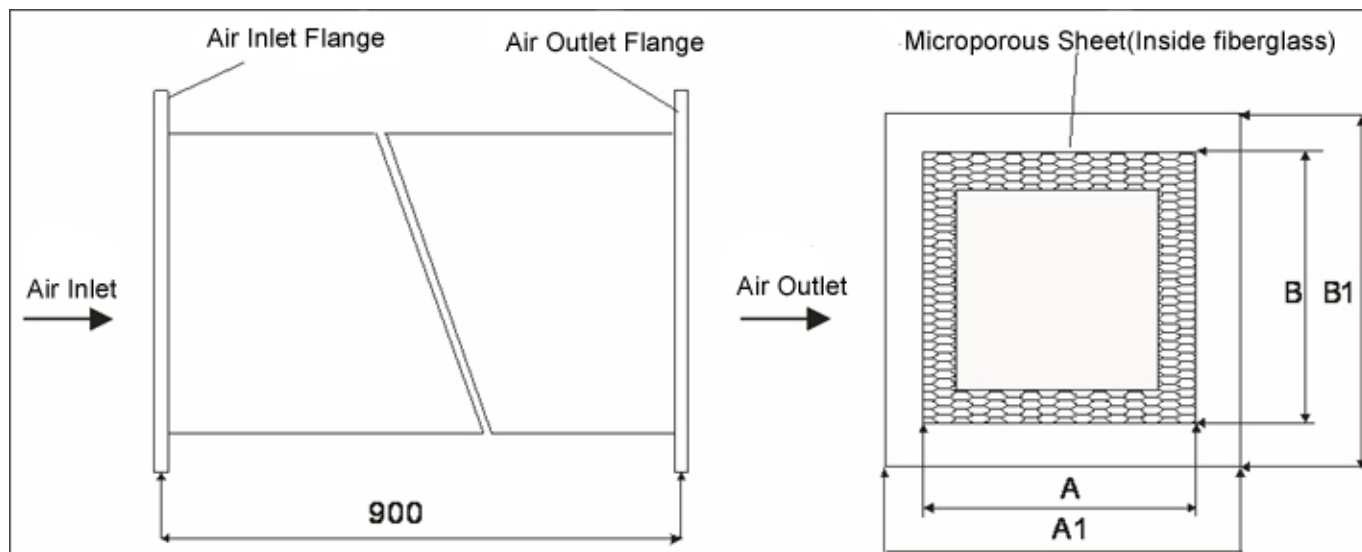

SIZE	A (mm)	B (mm)	A1(mm)	B1(mm)
V-TU-04	209	228	252	272
V-TU-05				
V-TU-06				
V-TU-07	260	260	303	304
V-TU-08				
V-TU-09	311	324	354	368
V-TU-10				
V-TU-12	362	387	405	431
V-TU-14	412	419	455	463
V-TU-16	463	482	506	526
V-TU-18	516	516	559	560

4. MULTI-OUTLET MUFFLER PLENUM BOX

If multi air outlets are requested on the VAV box, a multi-outlet muffler plenum box can attain an obvious anechoic effect. The connection sizes L and H are the same as the size of the VAV box outlet.

STANDARD CONFIGURATION:

- ◆ 0.8mm galvanized steel casing
- ◆ Inside galvanized micro-porous sheet
- ◆ Noise reduction material is 20mm super-thin fiberglass
- ◆ Flanged air inlet

◆ Cylindric air outlet

OPTIONAL ACCESSORIES

- ◆ Manual damper actuator in the air outlet
- ◆ Air outlet balance plate

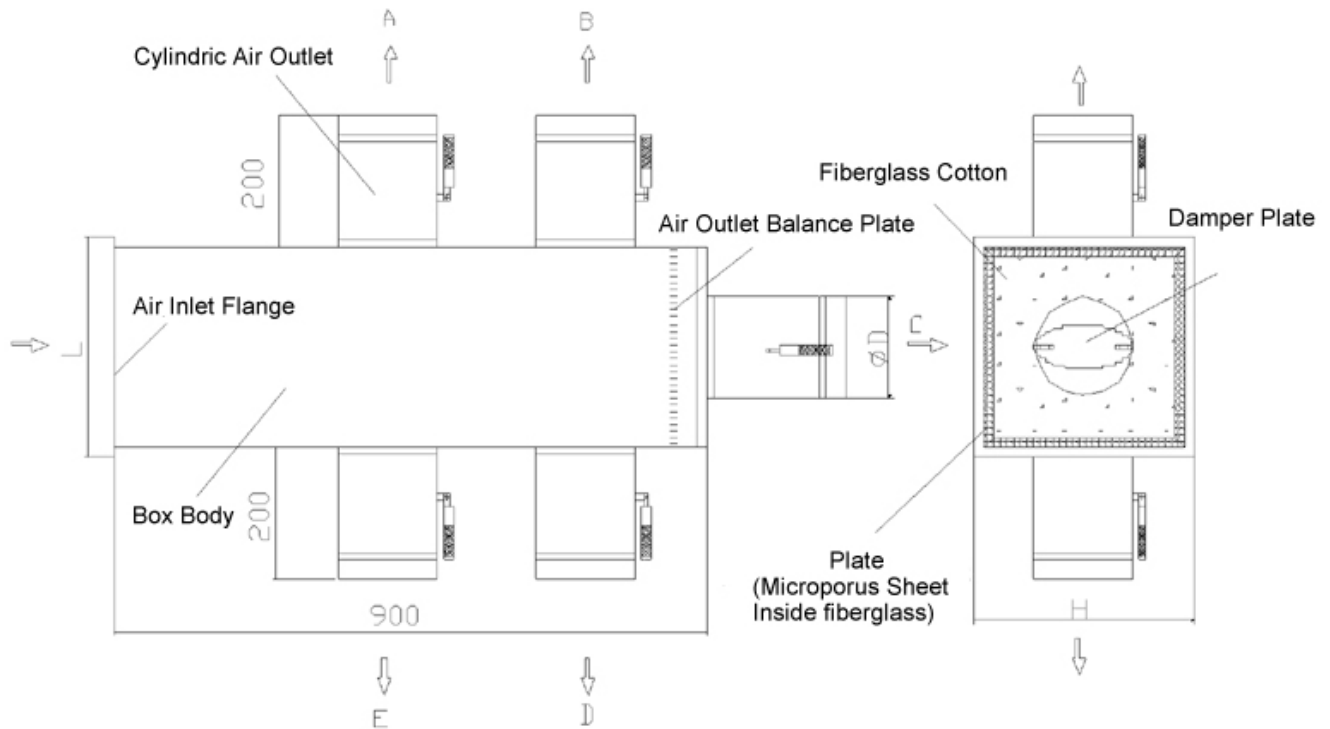

The configuration of the air outlet refers to above drawing. The cylindric outlet is the standard type, and the foursquare outlet is for option. For example, A-311X324-C-260X260 means multi-outlet muffler plenum box with A, C air outlets. The size of A is 311X324mm, the size of C is 260X260mm.

5. MULTI-OUTLET PLENUM BOX

If a VAV box needs to joint multi air outlets with low noise request, it's available to equip multi-outlet plenum box. The connection sizes L and H are the same as the size of VAV box outlet. The model selection refers to that of multi-outlet muffler plenum box.

STANDARD CONFIGURATION:

- ◆ 0.8mm galvanized steel casing
- ◆ Inside galvanized microporous sheet
- ◆ Noise reduction material is 20mm super-thin fiberglass

- ◆ Flange air inlet
- ◆ Cylindric air outlet

OPTIONAL ACCESSORIES

- ◆ Manual damper actuator in the air outlet
- ◆ Air outlet balance plate

6. DAMPER ACTUATOR

Sinro 6Nm damper actuator is suitable for all size VAV boxes usually.

OPTIONAL MODEL:

SRD02-06XXXXXX	on/off; floating type	on/off or floating control
SRD02-06024E	modulating type	0-10V control

Please see details in SRD02 damper actuator specification

7. Controller

Support BACnet or Lon communication

OPTIONAL BRANDS:

Delta controller	BACnet communication
Matrix controller	Lon communication
Reliable controller	BACnet communication

Please refer to their data sheet.